

Adjustable pipe support rollers



These adjustable pipe roller assemblies are designed to support HDPE, steel pipe as well as cast iron pipe. Rollers have heavy duty life time grease packed bearings. The A2 & A3 units have hand rails for easy adjustment. Rollers are made of polyurethane. Adjusting is done by removing two pins and a security pin.

The frame of the A4 is hot dip galvanized and can be stowed 4 units on top of each other. To adjust, one roller section is moved inside the frame. Adjustment of the A4L and A5 is done by moving the two roller sections. A pin will secure the position. A4 & A5 rollers are of 80 shore rubber.



A3

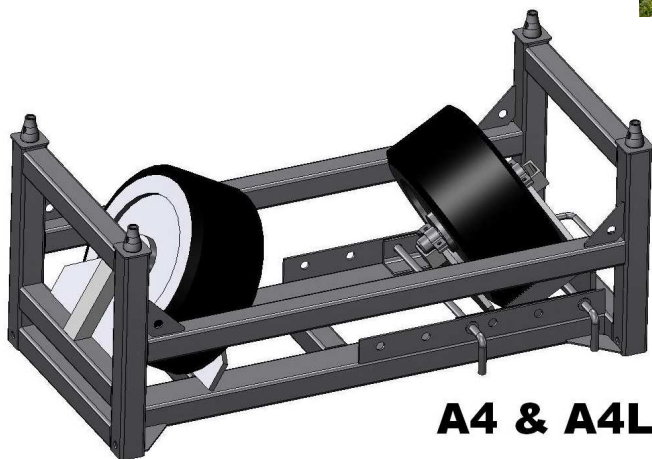

A4 & A4L



Type	Max. load (t)	Pipe Ø (mm)	L x B x H (cm)	Weight (kg)	€
A2	2,5	150 - 550	60 x 60 x 20	26	
A3	6	300 - 915	110 x 80 x 40	100	
A4	16	700 - 1230	150 x 70 x 60	335	
A4L	16	700 - 1430	175 x 77 x 65	365	
A5	20	800 - 1600	200 x 100 x 75	750	

Last update Aug. 2010

Marindco Deutschland GmbH

Wrister Straße 24
D 24576 Weddelbrook
e-mail: info@marindco.de

Tel: +49 (0) 4192 897 100
Fax: +49 (0) 4192 897 153
Internet: www.marindco.de